

# EXCEL SCREW PRESS



*Palm Oil Mill Equipment Specialist*

[www.excelmech.com.my](http://www.excelmech.com.my)

# SCREW PRESS

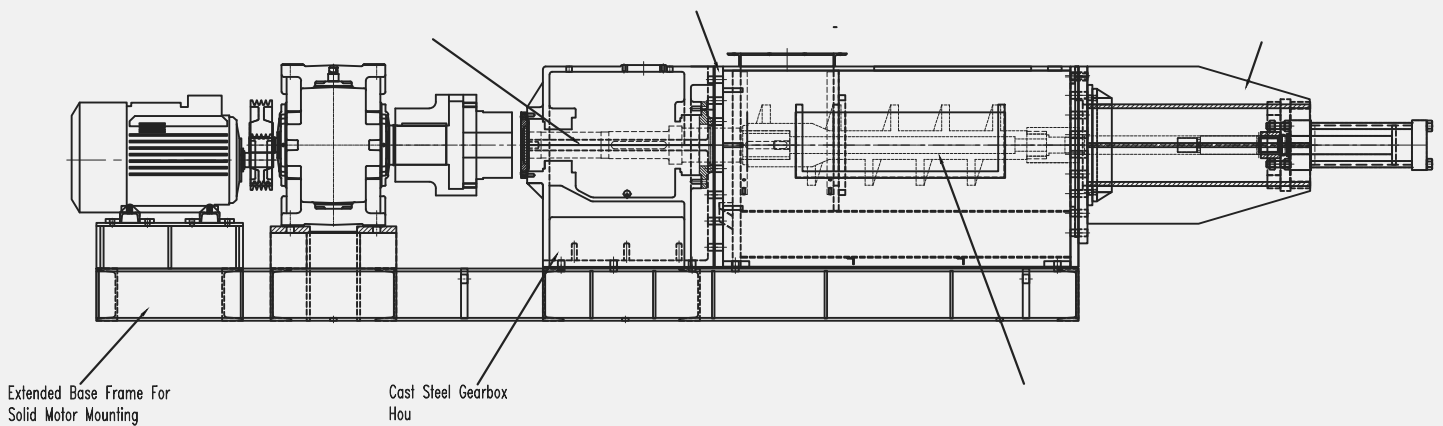

MODEL	EXCEL P15	EXCEL P20	EXCEL P25
Type	Double Worm Screw		
Capacity	15-17 tons FFB/hr	20-22 tons FFB/hr	25-27 tons FFB/hr
Motor	30kW (40hp)	45kW (60hp)	45kW (60hp)
Gearbox	Helical Gearbox		
Running Amp	35-50	50-70	50-70
Average Oil Loss (Dry Basis)	6-8%		
Average Nut Breakage	8-11%		
Pressing P late / Cone Pressu re	40-60 bar	50-70 bar	50-70 bar

For further information, please contact sales office, or:



**Excelmech Engineering Sdn. Bhd.** (Company No. 862039-X)

Lot 2828, Jln Kelkati 32/168, Off Jln. Sri Gambut Bukit Naga,  
Seksyen 32, 40460 Shah Alam, Selangor Darul Ehsan, Malaysia.  
Tel: 603-5167 1589 Fax: 603-5167 2588  
E-mail: [contact@excelmech.com.my](mailto:contact@excelmech.com.my)